

E-RC45

Rejilla de aletas reticuladas



Descripción E-RC45

Rejilla de retorno de aletas reticuladas de aluminio en forma de cuadrícula de 15 x 15 mm inclinada a 45°, fabricada con láminas de aluminio.

Fijación:

- ✓ Muelles con marco de E-MM, E-MAM, E-CLIPO o plenums montables E-PLEKIT.
- ✓ Pestillos con marco E-MM, E-MAM o E-TACO.
- ✓ Tornillos con marco E-MM.

Acabado: Aluminio anodizado o lacado blanco. Se pueden suministrar en otros colores bajo pedido.

Aplicaciones: Estas rejillas se utilizan en retornos situados en pared o en techo. La rejilla E-RC45 impide la visión del conducto. Mediante la regulación de caudal puede ajustarse el caudal aspirado de las distintas habitaciones.



Fijaciones E-RC45

Muelles

1

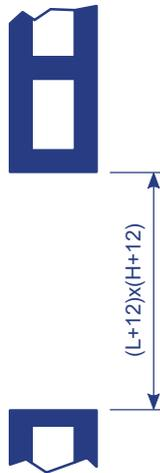

2

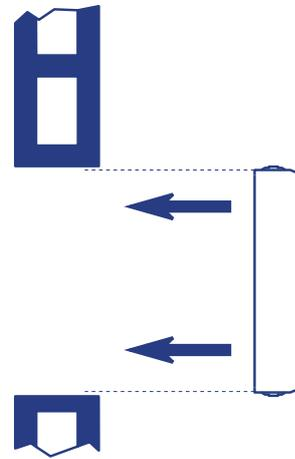

1. Abrir hueco en pared de medida (L+12) x (H+12).
2. Colocar el marco metálico (E-MM o E-MAM). Fijarlo a la pared con mortero o yeso.

3

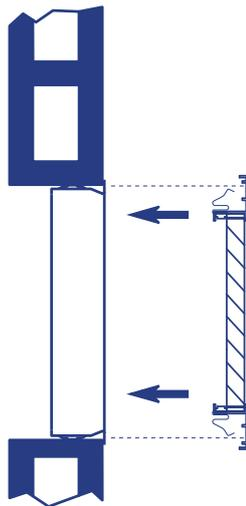

3. Colocar la rejilla con muelles dentro del marco metálico. Presionar primero un lado y luego el otro.



Fijaciones E-RC45

Mediante pestillos

1

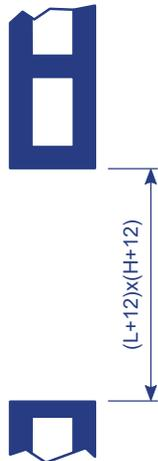

1. Abrir hueco en pared de medida $(L+12) \times (H+12)$

2

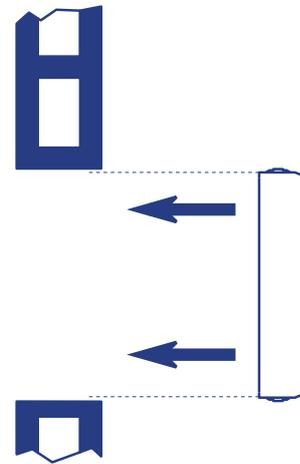

2. Colocar el marco metálico (E-MM o E-MAM). Fijarlo con mortero o yeso.

3

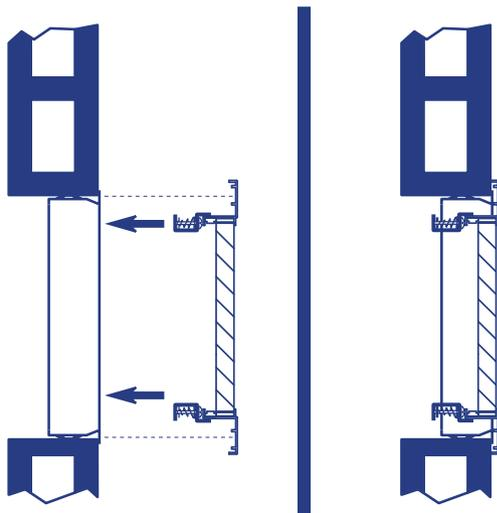

3. Colocar la rejilla con los pestillos cerrados.

4

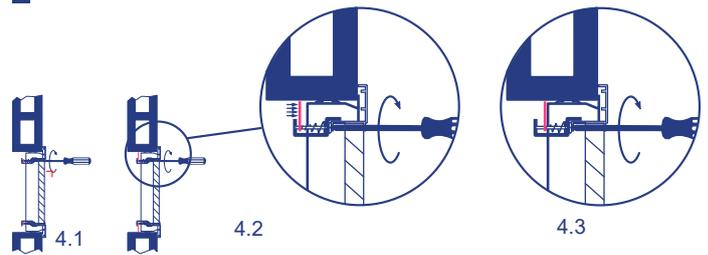

4.1 Girar tornillo mediante destornillador. El primer cuarto de vuelta la lengüeta del pestillo se coloca detrás del marco metálico.
4.2 Seguir girando el destornillador la lengüeta del pestillo se aproxima al marco.
4.3 La lengüeta se apoya con el marco. Cuando todos los pestillos de la rejilla están en esta posición la rejilla está completamente fijada.



Fijaciones E-RC45

Mediante tornillos

1

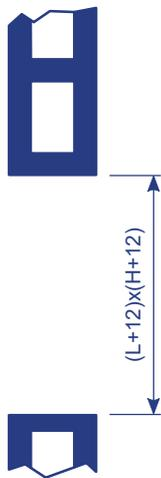

1. Abrir hueco en pared de medida (L+12) x (H+12)

2

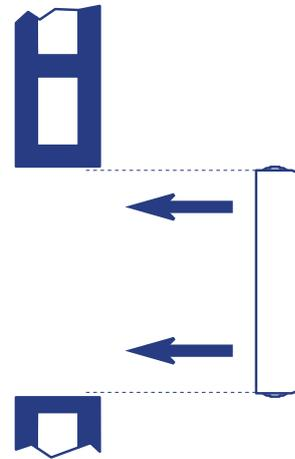

2. Colocar el marco metálico (E-MM o E-MAM). Fijarlo mediante mortero o yeso.

3

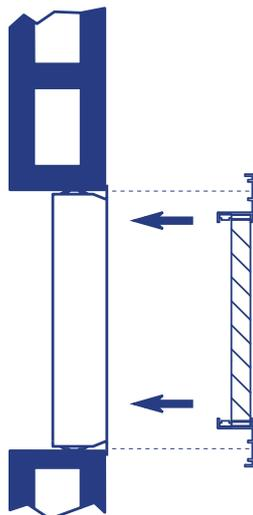

3. Colocar rejilla dentro del marco metálico.

4

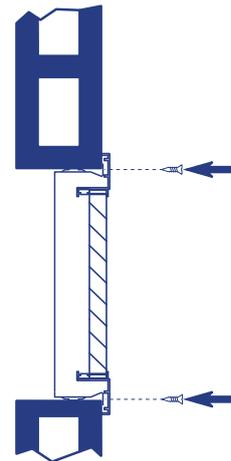

4. Colocar tornillos en los orificios del marco de la rejilla.

5

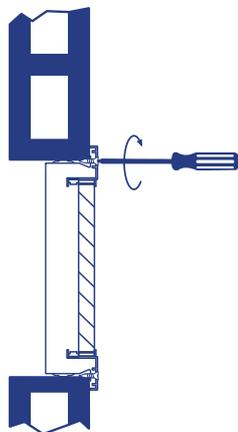

5. Atornillar.



Dimensiones E-RC45

Las dimensiones nominales (de pedido) vienen marcadas por las cotas L y H.

MEDIDA DEL HUECO	
Sin marco de montaje	L x H
Con marco de montaje	(L+12) x (H+12)

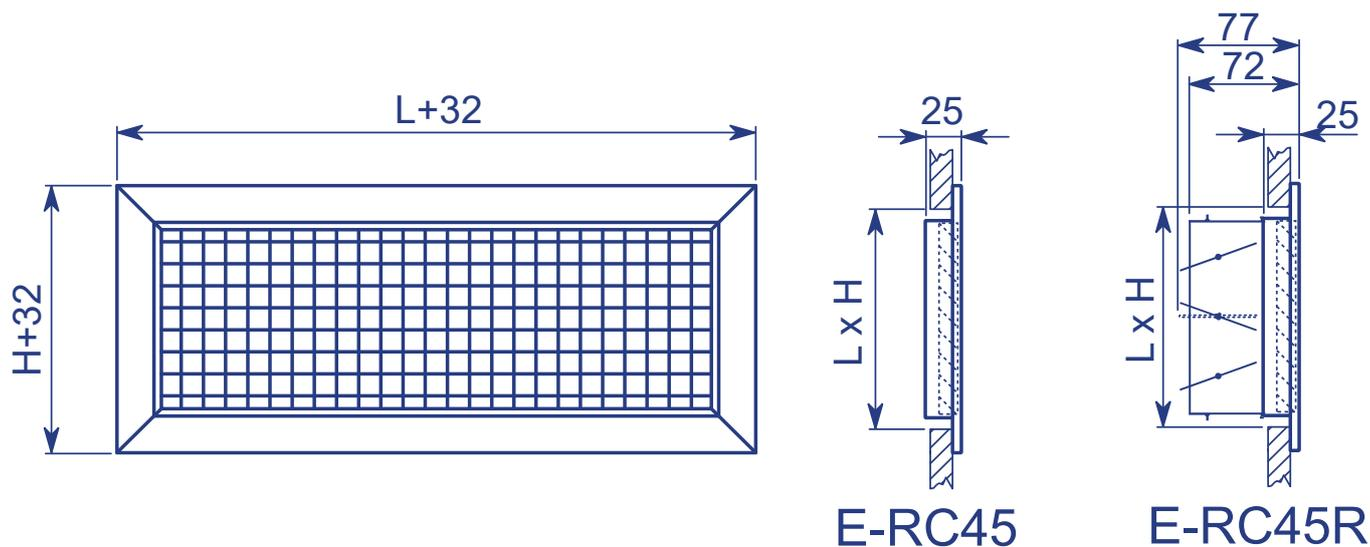

H \ L	100	150	200	250	300	350	400	450	500	600	700	800	900	1000
100	*	*	*	*	*	*	*	*	*	*	*	*	*	*
150	*	*	*	*	*	*	*	*	*	*	*	*	*	*
200	*	*	*	*	*	*	*	*	*	*	*	*	*	*
250	*	*	*	*	*	*	*	*	*	*	*	*	*	*
300	*	*	*	*	*	*	*	*	*	*	*	*	*	*
350	*	*	*	*	*	*	*	*	*	*	*	*	*	*
400	*	*	*	*	*	*	*	*	*	*	*	*	*	*
450	*	*	*	*	*	*	*	*	*	*	*	*	*	*
500	*	*	*	*	*	*	*	*	*	*	*	*	*	*

Nota: Las dimensiones indicadas en la tabla son estándar. Pueden fabricarse rejillas de otras dimensiones superiores o intermedias bajo pedido.



ACCESORIOS E-RC45

E-R: Compuerta de regulación de caudal de lamas opuestas, construido con perfiles de aluminio extruado. En posición de cierre las aletas quedan totalmente planas, mientras que en posición abierta las aletas quedan paralelas al flujo de aire.

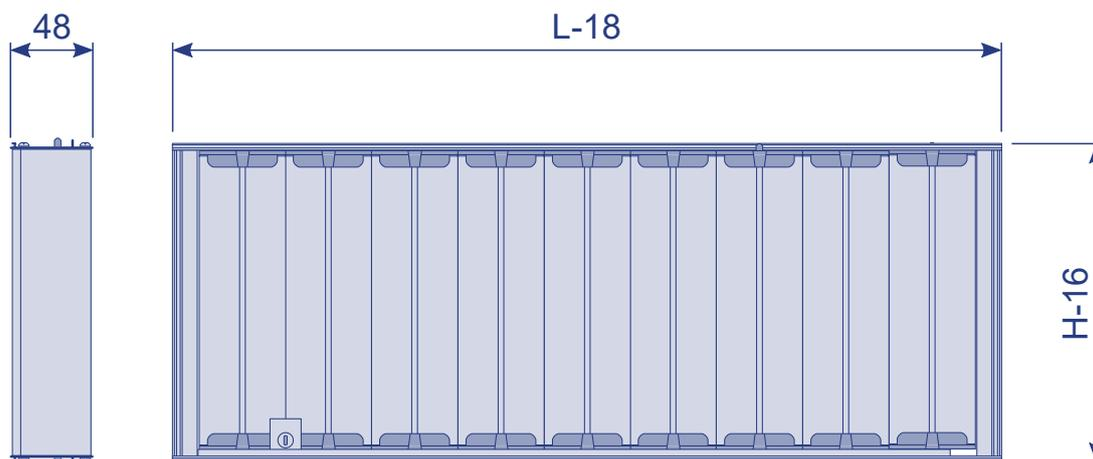

H \ L	150	200	250	300	350	400	450	500	550	600	650	700	750	800	850	900	950	1000
75	*	*	*	*	*	*	*	*	*	*	*	*	*	*	*	*	*	*
100	*	*	*	*	*	*	*	*	*	*	*	*	*	*	*	*	*	*
125	*	*	*	*	*	*	*	*	*	*	*	*	*	*	*	*	*	*
150	*	*	*	*	*	*	*	*	*	*	*	*	*	*	*	*	*	*
200	*	*	*	*	*	*	*	*	*	*	*	*	*	*	*	*	*	*
250	*	*	*	*	*	*	*	*	*	*	*	*	*	*	*	*	*	*
300	*	*	*	*	*	*	*	*	*	*	*	*	*	*	*	*	*	*
350	*	*	*	*	*	*	*	*	*	*	*	*	*	*	*	*	*	*
400	*	*	*	*	*	*	*	*	*	*	*	*	*	*	*	*	*	*

Nota 1: L y H son las dimensiones nominales de la rejilla.

Nota 2: Pueden fabricarse regulaciones de medidas especiales en cota H.

Nota 3: En cota L las regulaciones de caudal deben ser múltiplo de 50 mm. Cuando una rejilla sea de medida especial en cota L no múltiplo de 50 mm se colocará la regulación de mayor medida que sea múltiplo de 50 mm.

Nota 4: No son posibles regulaciones de caudal de más de 1000 x 400. En rejillas de mayor medida se colocarán varias regulaciones independientes.



Accesorios E-RC45

Funcionamiento E-R:

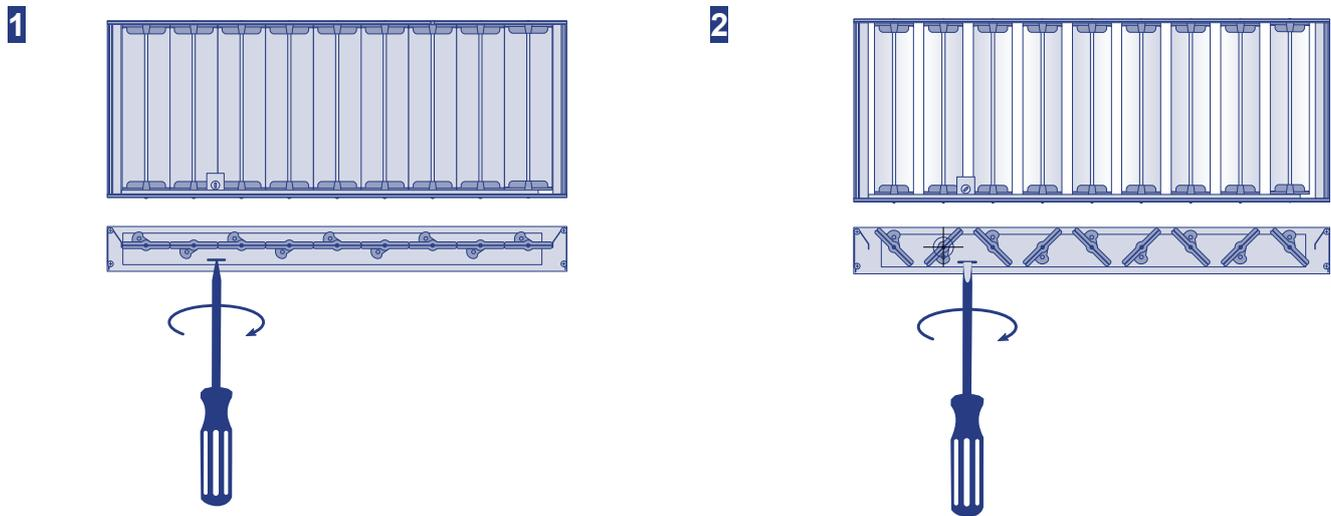

1. Girar corona mediante un destornillador hasta conseguir el grado de apertura deseado.

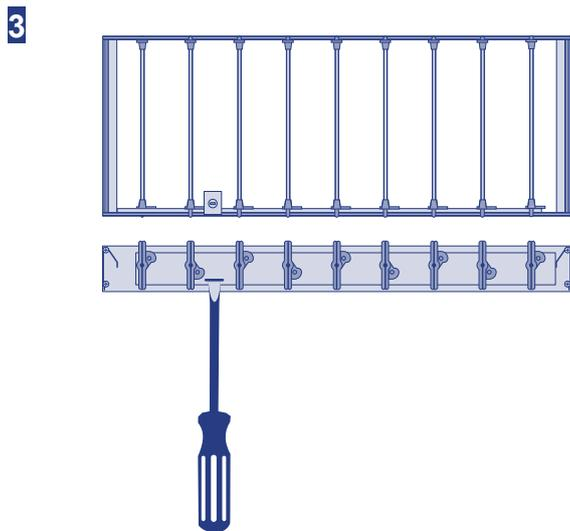



Accesorios E-RC45

E-RM: Motorización de la compuerta de regulación. Puede ser de 24 V o 220 V, según se especifique en el pedido.

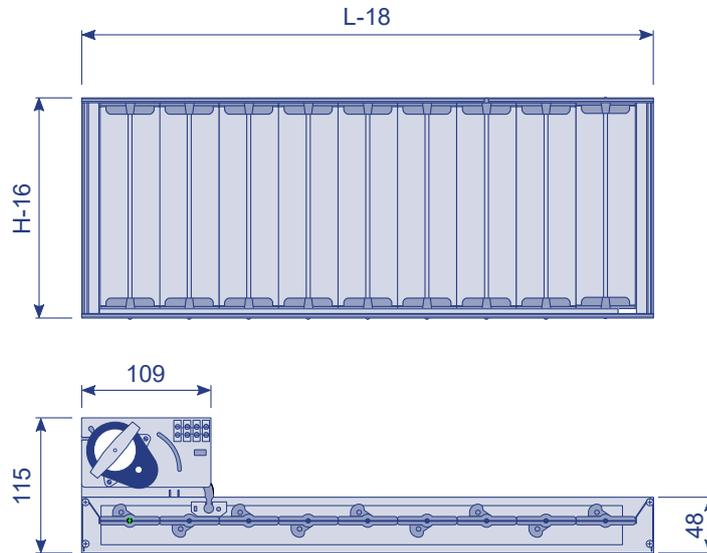

Esquema eléctrico:

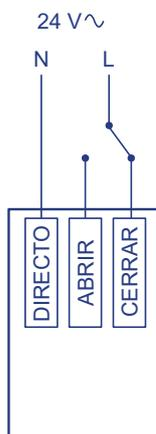
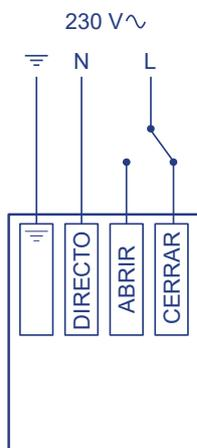

Características eléctricas	
Voltaje	230 / 24 V~
Tipo de actuación	Todo/nada
Tolerancia del voltaje	-10%....+15%
Frecuencia	50 Hz
Potencia nominal	1,5 W
Control	3 puntos (todo - nada)
Final de carrera	No
Tiempo de maniobra (apertura o cierre)	12 s
Mantenimiento	No precisa
Temperatura de operación	-15....+55°C
Temperatura de almacenamiento	-20....+60°C



Plenums E-RC45

02.276: Plénium montado realizado en chapa galvanizada con uno o más cuellos circulares (u ovalados) del mismo diámetro situado en el lado opuesto al que va colocado la rejilla.

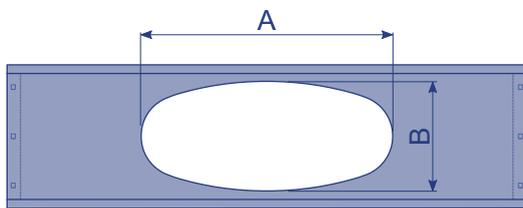
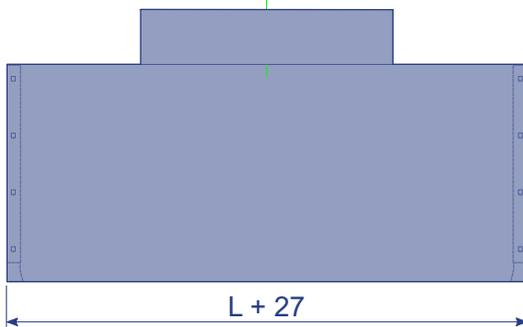

ØD _{cond.} (mm)	Tipo de cuello	A (mm)	B (mm)
100	Elíptico	107	90
	Circular	100	100
125	Elíptico	150	90
	Circular	125	125
150	Elíptico	190	90
	Circular	150	150
160	Elíptico	206	90
	Circular	160	160
200	Elíptico	270	90
	Circular	200	200
250	Elíptico	281	190
	Circular	250	250
300	Circular	300	300

Nota 1: Posibles otras cotas bajo pedido

Nota 2: Cota H mínima de rejilla B+10 mm

02.277: Plénium montado realizado en chapa galvanizada con uno o más cuellos circulares (u ovalados) del mismo diámetro situado en el lateral de la rejilla.

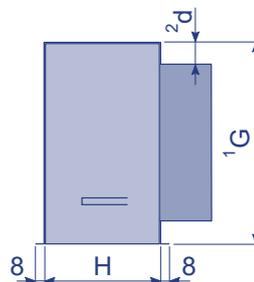
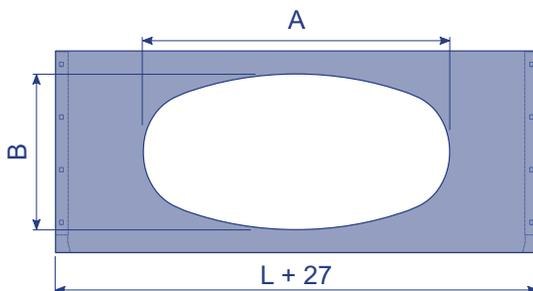

ØD _{cond.} (mm)	Tipo de cuello	A (mm)	B (mm)
100	Elíptico	107	90
	Circular	100	100
125	Elíptico	150	90
	Circular	125	125
150	Elíptico	190	90
	Circular	150	150
160	Elíptico	206	90
	Circular	160	160
200	Elíptico	270	90
	Circular	200	200
250	Elíptico	281	190
	Circular	250	250
300	Circular	300	300

Nota 1: Cota G según pedido

Nota 2: Cota mínima 25mm



Tablas de selección E-RC45

Altura	Longitud												
500													
400												400	
350											400		
300								300		400	500	600	
250							300		400	500		600	
200			200			300		400		500	600	700	800
150		200		300		400		500	600	700	800	900	1000
100	200	300	400		500	600	700	800	900	1000			

m³/h

100	Vel. [m/s]	1,8												
	P [mm.c.a.]	0,7												
	Nv.Son [dB(A)]	13												
150	Vel. [m/s]	2,6	1,7											
	P [mm.c.a.]	1,6	0,6											
	Nv.Son [dB(A)]	22	13											
200	Vel. [m/s]	3,5	2,3											
	P [mm.c.a.]	2,8	1											
	Nv.Son [dB(A)]	30	21											
300	Vel. [m/s]	5,3	3,4	2,6	2,1									
	P [mm.c.a.]	5,6	2,2	1,6	0,4									
	Nv.Son [dB(A)]	38	32	26	22									
400	Vel. [m/s]		4,6	3,5	2,8	2,8	2,3							
	P [mm.c.a.]		4	2,8	0,6	1,5	1							
	Nv.Son [dB(A)]		35	34	30	29	25							
500	Vel. [m/s]			4,4	3,4	3,5	2,9	2,5	2,2					
	P [mm.c.a.]			4,4	3,3	2,8	1,6	1,2	0,9					
	Nv.Son [dB(A)]			37	35	34	31	29	26					
600	Vel. [m/s]					4,2	3,4	3	2,6	2,3	2,1			
	P [mm.c.a.]					3,3	2,2	1,7	1,3	1	0,9			
	Nv.Son [dB(A)]					38	36	34	31	28	23			
700	Vel. [m/s]							3,5	3	2,7	2,4	2	1,6	
	P [mm.c.a.]							2,4	1,7	1,4	1,2	0,8	0,2	
	Nv.Son [dB(A)]							37	36	32	31	27	22	
800	Vel. [m/s]								3,5	3,1	2,8	2,3	1,8	1,7
	P [mm.c.a.]								2,3	1,8	1,5	1	0,3	0,3
	Nv.Son [dB(A)]								38	36	35	31	26	24

Vel = Velocidad efectiva

P = pérdida de carga

Nv. Son. = Nivel de ruido



Tablas de selección E-RC45

Altura	Longitud												
500								500	600	700	800	900	1000
400				400			500	600	700	800	900	1000	
350			400			500	600	700	800	900	1000		
300		400	500			600	700	800	900	1000			
250	400	500			600	700	800	1000					
200	500	600	700	800	900	1000							
150	700	800	900	1000									
100	1000	1200											

m³/h

900	Vel. [m/s]	3,1	2,6	2,1	1,9	1,5								
	P [mm.c.a.]	2	1,3	0,4	0,4	0,2								
	Nv.Son [dB(A)]	38	34	29	27	23								
1000	Vel. [m/s]		2,9	2,3	2,1	1,7	1,6							
	P [mm.c.a.]		1,6	0,5	0,5	0,3	0,3							
	Nv.Son [dB(A)]		38	31	30	26	26							
1200	Vel. [m/s]			2,8	2,5	2,1	1,9	1,6						
	P [mm.c.a.]			0,7	0,7	0,4	0,4	0,3						
	Nv.Son [dB(A)]			35	34	31	30	26						
1400	Vel. [m/s]				2,9	2,4	2,1	1,9	1,6	1,5				
	P [mm.c.a.]				0,9	0,5	0,5	0,4	0,2	0,3				
	Nv.Son [dB(A)]				38	34	34	30	27	25				
1600	Vel. [m/s]						2,4	2,1	1,8	1,7	1,4			
	P [mm.c.a.]						0,6	0,5	0,3	0,4	0,2			
	Nv.Son [dB(A)]						37	34	31	29	25			
1800	Vel. [m/s]							2,4	2,1	1,9	1,5	1,3		
	P [mm.c.a.]							0,6	0,4	0,5	0,3	0,2		
	Nv.Son [dB(A)]							37	34	32	27	25		
2000	Vel. [m/s]								2,3	2,2	1,7	1,5	1,3	
	P [mm.c.a.]								0,5	0,6	0,3	0,2	0,2	
	Nv.Son [dB(A)]								36	35	30	28	25	
2500	Vel. [m/s]									2,7	2,2	1,9	1,7	1,6
	P [mm.c.a.]									0,9	0,5	0,4	0,3	0,3
	Nv.Son [dB(A)]									38	36	34	31	30
3000	Vel. [m/s]										2,6	2,2	2	1,9
	P [mm.c.a.]										0,8	0,5	0,5	0,4
	Nv.Son [dB(A)]										40	37	34	33
3500	Vel. [m/s]													2,2
	P [mm.c.a.]													0,5
	Nv.Son [dB(A)]													36

Vel = Velocidad efectiva

P = pérdida de carga

Nv. Son. = Nivel de ruido



Tablas de selección E-RC45

Áreas efectivas (m²)

H \ L	100	150	200	250	300	350	400	450	500	600	700	800	900	1000
100	0,006	0,009	0,013	0,017	0,021	0,024	0,028	0,032	0,036	0,043	0,050	0,058	0,065	0,073
150	0,009	0,015	0,021	0,027	0,033	0,039	0,045	0,052	0,057	0,070	0,082	0,094	0,106	0,118
200	0,013	0,021	0,030	0,038	0,046	0,054	0,063	0,071	0,079	0,096	0,112	0,129	0,145	0,162
250	0,017	0,027	0,038	0,048	0,059	0,069	0,080	0,091	0,101	0,122	0,143	0,164	0,185	0,206
300	0,021	0,033	0,046	0,059	0,072	0,085	0,097	0,110	0,123	0,149	0,174	0,200	0,226	0,251
350	0,024	0,039	0,054	0,069	0,085	0,100	0,115	0,130	0,145	0,175	0,205	0,235	0,265	0,295
400	0,028	0,045	0,063	0,080	0,097	0,115	0,133	0,149	0,167	0,201	0,236	0,271	0,305	0,340
450	0,032	0,052	0,071	0,091	0,110	0,130	0,149	0,169	0,189	0,228	0,267	0,306	0,346	0,385
500	0,036	0,057	0,079	0,101	0,123	0,145	0,167	0,189	0,210	0,254	0,298	0,341	0,385	0,429
600	0,043	0,070	0,096	0,122	0,149	0,175	0,201	0,228	0,254	0,307	0,360	0,413	0,466	0,518
700	0,050	0,082	0,112	0,143	0,174	0,205	0,236	0,267	0,298	0,360	0,422	0,483	0,546	0,607
800	0,058	0,094	0,129	0,164	0,2	0,235	0,271	0,306	0,341	0,413	0,483	0,554	0,625	0,696
900	0,065	0,106	0,145	0,185	0,226	0,265	0,305	0,346	0,385	0,466	0,546	0,625	0,706	0,786
1000	0,073	0,118	0,162	0,206	0,251	0,295	0,340	0,385	0,429	0,518	0,607	0,696	0,786	0,874

Ejemplo de selección de rejilla

Datos: Caudal a impulsar Q = 500 m³/h

Nivel sonoro Nv. Son. = 30 dB(A)

Altura	Longitud													
500														
400										400				
350										400				
300							300		400	500	600			
250						300		400	500		600			
200			200		300		400		500	600	700	800		
150			200		300		400		500	600	700	800	900	1000
100		200	300	400	500	600	700	800	900	1000				

m³/h

500	Vel. [m/s]			4,4	3,4	3,5	2,9	2,5	2,2					
	P [mm.c.a.]			4,4	3,3	2,8	1,6	1,2	0,9					
	Nv. Son [dB(A)]			37	35	34	31	29	26					

Resultados: Medida 700 mm x 100 mm

Velocidad Vel = 2,5 m/s

Pérdida de carga P = 1,2 mm.c.a.

Nivel sonoro Nv. Son = 29 dB(A)



Referencia de pedido:

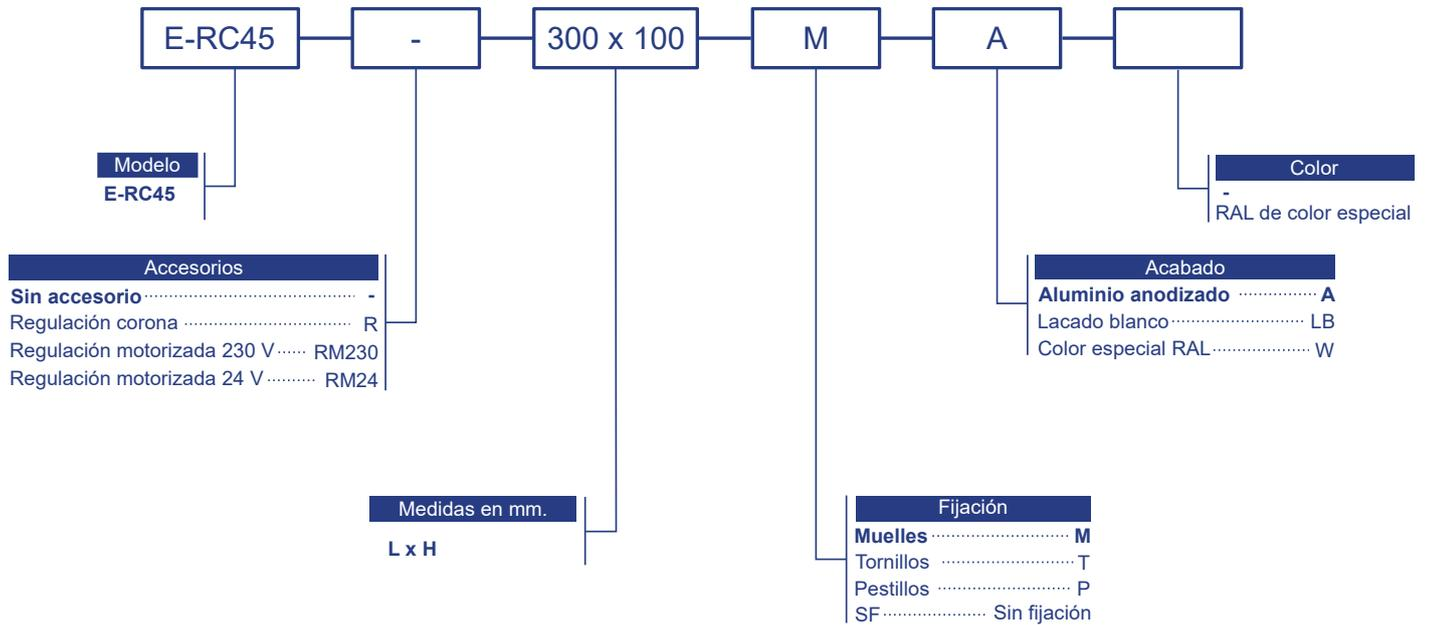

Nota: Las opciones señaladas en negrita serán las que se utilizarán en caso de no especificación por parte del cliente.

EJEMPLO: E-RC45-300x100-M-A: Rejilla E-RC45 de 300 mm de longitud y 100 mm de altura con fijación por muelles, anodizada en aluminio.